

Specification

HT-A02

1 Product Spec

- Max. Load:30kg
- Net Weight:2kg

UNIT : mm

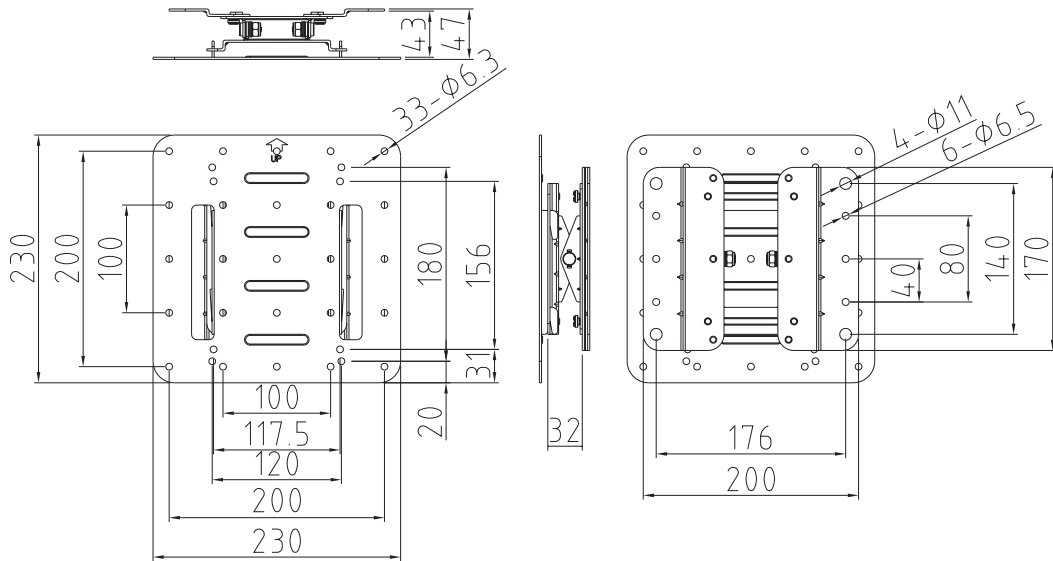

2 Parts Name

- Please check out all parts.

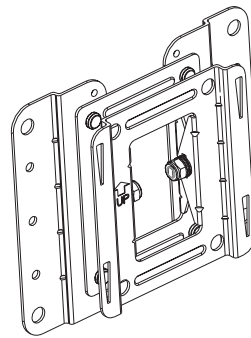
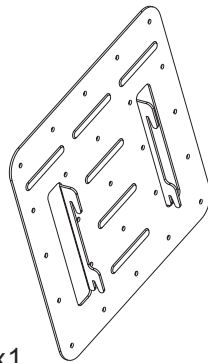

(A) TV Bracket x1

(B) Wall Bracket x1

(F)  M4x15 Screw x6

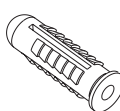
(C)  Φ 10X56 Wall Anchor x6

(G)  M6x15 Screw x6

(D)  12#x1½ Wood Screw x6

(H)  5/16 x 2¼ Wall Anchor x4

(E)  Φ 4 Sleeve x6



Registered design and patent pending. All rights reserved

Installation

HT-A02

1 Step 1

- The wall must be at least 5cm thick.
- For a wooden wall, please choose wood screws 6pcs $\phi 5.5 \times 38 \text{mm}$ (D)
- For a concrete wall, please choose wall anchors 4pcs $\phi 10 \times 56 \text{mm}$ (H)

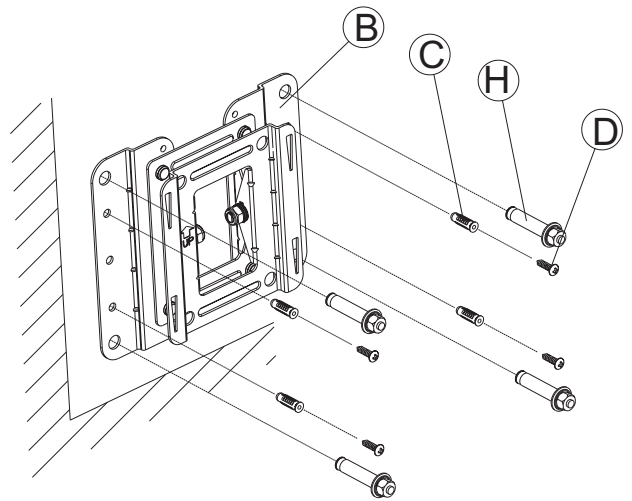

2 Step 2

- At the time of installation, make sure that 2 people hold the LCD TV.
- Make sure the LCD TV is turn off before installing.
- Use 6 pcs M4x12 (F) screws and 6 pcs $\phi 4$ (E) sleeve to assemble the TV bracket to the LCD TV.

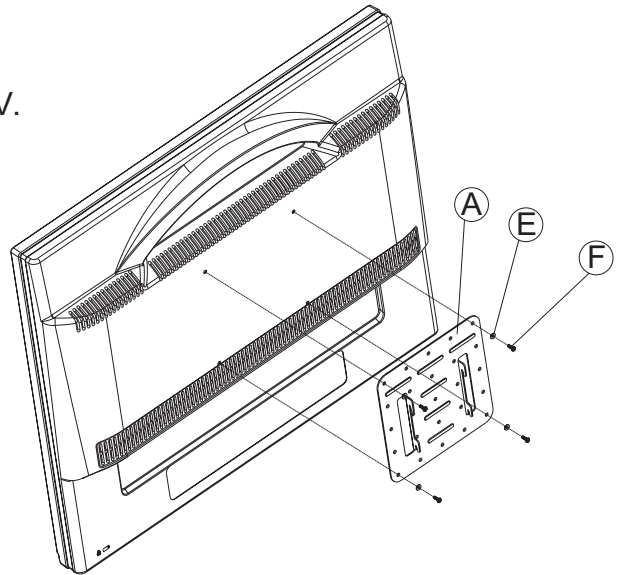

3 Step 3

- Make sure the two brackets are locked and secure.

4 Step 4

- Tighten the fixed screw to lock the TV in place.

